



PC-Wanderer

Operating Manual

For use with PC-Wanderer software
issue 1.1.0 or later.

WANDERER GSM

INSTALLATION INSTRUCTIONS

Introduction:

Wanderer GSM is a unique blend of alarm system and super-low-power monitor / controller unit. It may be used in a variety of applications, eg:

- *Open-air site / outbuildings alarm / control / monitoring*
- *Marine / Holiday home / Caravan alarm*
- *Vending machine alarm / control / monitoring*
- *8 I/P Fast-Format communicator*
- *20 message SMS dialler*

Key features:

- *Dual-band GSM 900/1800 - Fast Format / SMS*
- *8 Wired zones / inputs*
- *8 Wireless zones / inputs on 200 unique channels (433MHz)*
- *2 programmable outputs (50mA at 0v)*
- *Speaker / piezo sounder output*
- *Super-low power consumption @1mA (can run for 6 months or more from a single 12v 7Ahr battery!)*

Availability:

WAN -100	Standard Wanderer	Steel housing (250 x 320 x 90mm) fitted 0.75A PSU, integral sounder and key-switch. Provision for 12v 7Ahr battery.
WAN -200	Marine Wanderer	Polycarbonate IP65 housing (230 x 300 x 110mm) fitted key-switch. No power supply (12v operation) Provision for 12v 7Ahr battery.
WAN -300	Industrial Wanderer	GRP lockable IP65 housing (400 x 300 x 180mm) fitted 0.75A PSU, integral sounder and key-switch. Provision for 12v 7Ahr battery.
WAN -400	Wanderer Chassis	Wanderer control electronics and antennae mounted on steel chassis to fit into your housing. Requires 12v DC supply, control key-switch, etc.

Specifications:

Power:	9 to 14v DC	
Current consumption	1 mA	Quiescent, power saving mode
	50mA	Quiescent, normal mode
	500mA	During GSM transmission
	150mA	Sounder
Power supply	Input: 230-240v AC 75mA Output: 12v DC 750mA	If fitted
Battery	12v 7 Ah (minimum)	
Control	Key or other electrical switch via wired inputs	
	Remote via SMS messages	Not available in power saving mode
Outputs	Sounder, plus 3 @ 50mA, fully programmable	
Wired Inputs	8 wired fully configurable as detection zones or control inputs	May be configured for use with NO (or NC) loop, voltage start, or variable analog inputs
Wireless (RF) inputs	Integrated 433MHz super-regen receiver/decoder. 200 channels available. 8 wireless detectors plus 2 status channels	
Signalling	8 channels, Fast Format	Does NOT use DTMF tones
	SMS signalling to 4 numbers. Up to 40 different (160 character) messages available	
DIMENSIONS: (w.h.d)	Standard Wanderer	250 x 320 x 90 (exc. antennae)
	Industrial Wanderer	300 x 400 x 180
	Marine Wanderer	230 x 300 x 110
	Wanderer Chassis	159 x 275 x 32

Compliance Statement:

Wanderer GSM complies with the requirements of relevant European Directives, as specified in the Declaration of Conformity:



PRODUCT DECLARATION OF CONFORMITY

Manufacturer: Castle Care-Tech Ltd.
North Street
Winkfield
Nr. Windsor
Berkshire
SL4 4SY
England

Details of Equipment: 'Wanderer GSM' Alarm Control / Signalling unit

Declaration: Under our sole responsibility, we hereby declare that the product detailed above conforms with the essential requirements of the Directives identified below, conforming to the standards mentioned:

EMC Directive 89/336/EC as amended by 92/31/EC EN.50130-4 for Immunity
EN.50081 Part 1 for Emissions

Low Voltage Directive 73/23/EC as amended by 93/68/EC EN.60950

R&TTE Directive 1995/5/EC Radio Receiver: I-ETS 300 200
GSM Module: TBR 19, 20, 31 & 32
ETS 300 342-1

The conformity assessment procedure referred to in article 10 (3) and Annex II of Directive 1995/5/EC have been followed.

The technical documentation for this product is held at our Winkfield address.

Authorised Signature:

Issued:

30 March 2001

J. A. Lamb, Managing Director



Castle Care•Tech Ltd
North Street Winkfield Berkshire SL4 4SY
☎ +44(0)1344 886446 ☎ +44(0)1344 890024
✉ sales@castle-caretech.com 🌐 www.castle-caretech.com

Registered in England 2443917



It is essential that equipment and wiring be installed without affecting safety measures, and to avoid degrading EMC performance.

Warranty

Castle Care-Tech Ltd. will repair or replace (at our discretion) any product developing a fault within 12 months, free of charge.

If the failure was caused by operating the unit outside of its specifications, by physical damage, or by unauthorised modifications, we reserve the right to raise an appropriate repair charge.

Products for repair should be returned to the factory, suitably packed to prevent damage (including damage from electrostatic discharges) and be accompanied by full details of the fault, and the full return address.

Training:

Training courses may be arranged on application to the Sales office.

Installation:

Ensure that the Wanderer unit is located clear of metallic objects, etc., which could impair the range of the wireless detectors or GSM transmissions.

Mount the unit securely in position.

MAINS ELECTRICITY IS DANGEROUS!

The mains connection (if used) should comply with BS.7671, and be made by a competent person from the consumer unit or an unswitched fused spur outlet. The cable should be routed into the housing adjacent to the connector, and NOT looped within the housing, to avoid degrading the EMC performance.

CAUTION: Disconnect mains supply before removing the cover. Never add equipment to the system with power applied.

Mount other equipment in suitable locations – taking care to ensure that detectors are sited for maximum effectiveness and minimum environmental disturbance – and wire to the Control unit. If wiring is to be run in an electrically ‘noisy’ environment, the use of screened cable is recommended.

Wireless detectors should be mounted clear of metallic objects that could impair their signalling range.

NOTE: If Wanderer must be mounted in an area screened from GSM transmissions, or if the GSM signalling is found to interfere with wireless detector reception, the GSM antenna may be relocated remotely from the Wanderer unit using the 4-metre extension cable (WAN-600).

Wanderer Printed Circuit Board:

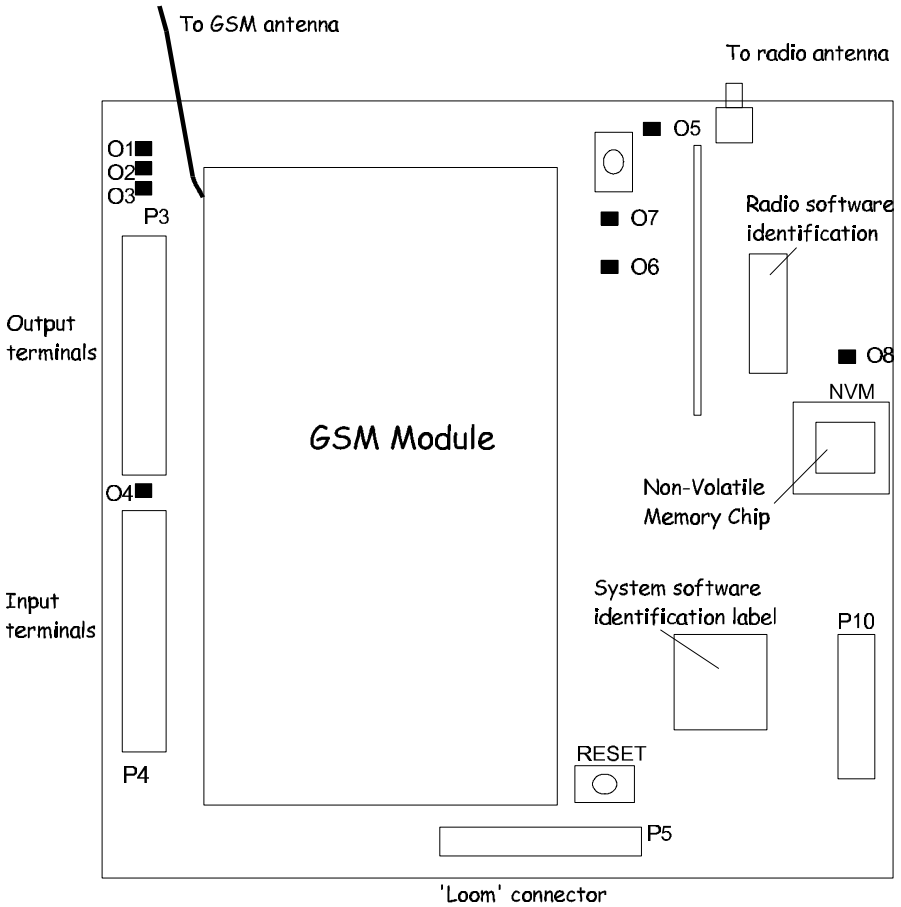

The indications are:

O1	GSM Signal strength	O5	RF signal received
O2	NB a more accurate reading will be obtained from a mobile phone using the same network.	O6	General Fault
O3		O7	Power / OK
O4	SIM Card error	O8	NVM Fault

Also: GSM (green) LED mounted on GSM module

Note: The indications on the unit are illuminated only at strategic times, in order to preserve the ultra-low power consumption of the unit.

Wiring:

a) Wiring the inputs / zones:

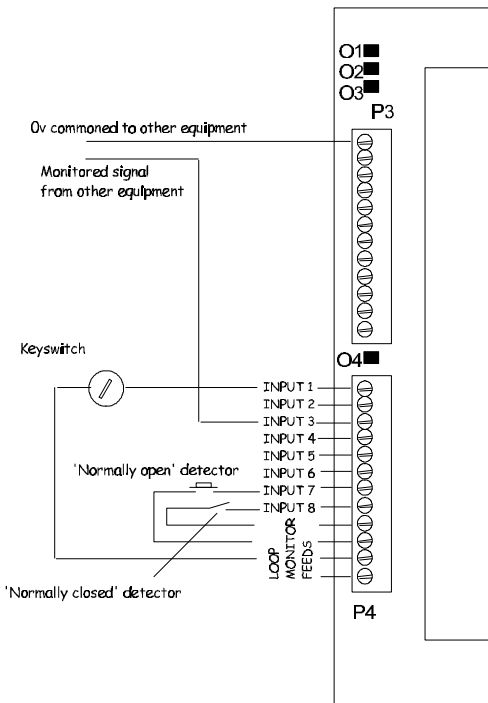

For the purposes of illustration, Input 1 is shown wired as a Keyswitch input – for example to 'set / unset' the system.

Input 3 is shown wired to monitor an output voltage from another piece of equipment – this may be a 'go-no go' switched output or a variable 'analog' output (note the commoned '0v connection, which is essential).

Input 7 is wired as a zone monitoring a 'normally open' circuit, and input 8 as a zone monitoring a 'normally closed' circuit.

Note the provision of four feeds for these loop monitors (maximum two circuits per feed).

Any input may be configured as required.

ANALOGUE SIGNALS MAY BE MONITORED VIA ZONES / INPUTS 1 to 6 ONLY.

NOTE: The wiring loom supplied with Wanderer units includes connections duplicating the zone/input 1 and 2 connections. On 'Standard' and 'Industrial' specification Wanderer units these are pre-wired to the Keyswitch and Housing Tamper switch. When the loom connections are used, the input terminals must NOT be connected.

To use Inputs 1 and 2 to monitor analogue input signals, simply transfer the keyswitch and tamper wiring to zone / inputs 7 and 8, and adjust the programming accordingly.

b) Wiring the Outputs:

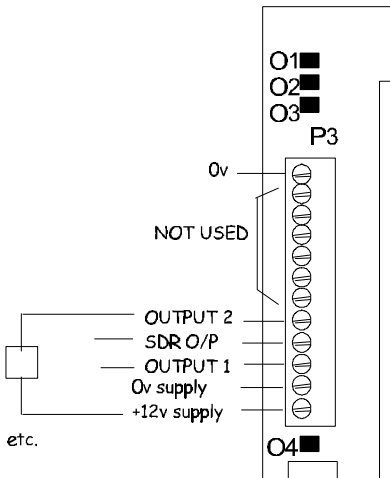

NOTE that these outputs provide 0v when live, with a MAXIMUM drive capacity of 50mA.

These are 'open collector' outputs – if +12v when inactive is required, external pull-ups must be provided.

Outputs 1 and 2 are programmable. Sounder O/P provides DC voltage (0v) whilst main sounder output is live.

If additional switching current capability is required, relay modules may be used.

c) Loom Connections:

'Standard' and 'Industrial' Wanderer units have the loom connections factory fitted as follows:

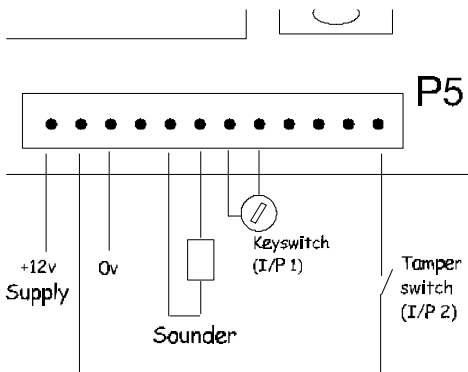

CONNECTIONS:

- 1 Red +12v SUPPLY
- 2 Black Input 2 feed
- 3 Black 0v SUPPLY
- 5 Blue Sounder -ive
- 6 White Sounder +ive
- 7 Yellow Input 1 feed
- 8 Yellow Input 1 return (keyswitch)
- 12 Black Input 2 return (tamper)

NOTES:

1. If an alternative sounder is to be used, the pre-wired unit **MUST** be disconnected, or use terminals shown above.
2. The looms on the first batch of units from the factory - serial numbers 221902-221907) - differ from this specification.

Wireless (RF) Zones:

The Wireless zones (Numbers 9 to 16) may be used with the following radio detectors:

- VA-511 PIR Movement detector
- VA-520 Smoke Detector
- VA-530 Break Glass Detector
- VA-540 Window / Door Contact (surface mount)
- VA-560 Personal Attack pendant / key fob.
- VA-570 Universal transmitter module.

NOTE: These detectors MUST be supplied by Castle Care-Tech Ltd. to ensure compatible with the integrated wireless receiver. Standard 'Visonic' detectors are NOT compatible.

'Tamper' and 'low battery' signals from radio detectors report to Wanderer as inputs 17 and 18 respectively.

Note that the range of the detector transmissions are restricted (compared to the standard Visonic products) by the ultra-low current receiver used.

CODING OF WIRELESS DETECTORS

Setting up the Wireless detectors is done in two stages. Note that the style of switch, and PCB labelling varies between detectors, but the principles outlined apply to all variations:

1. Selecting the System Receiver Channel

This must be set up to match the channel selected in software at the receiver unit. Channels available are 1 to 200.

Identify the **8-way** switch on the detector, and set switches to the 'ON' position to select the address required. The switches select the channel by binary code, with switches equivalent to:

Switch:	Code:	Simply move switches to the 'ON' position to add up to the address required.	eg: The channel selected in this example is 1.
1	1	NOTE: address 122 is a factory test setting and must NOT be used.	
2	2		
3	4		
4	8		
5	16		
6	32		
7	64		
8	128		

2. Selecting the Zone / Input Address

This must be set up to match the zone number programmed in software at the receiver unit.

Identify the **4-way** switch on the detector, and set switches to the 'ON' position to select the address required. The switches select the channel by binary code, with switches equivalent to:

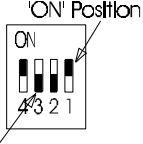
Switch:	Code:		
1	1	Simply move switches to the 'ON' position to add up to the address required. NOTE: addresses below 9 should NOT be used	eg: The address selected in this example is 10. 
2	2		
3	4		
4	9 (always on)		

Note: The walk test facility will respond to all valid wireless detectors within range, even if not programmed.

The SIM Card:

In order for the GSM unit to function, a 'SIM' card must be inserted. This is NOT factory fitted, leaving the choice of network, tariff, etc. to the installer.

The ideal SIM card is a "multi-network resilient" type, that will hunt and log on to the strongest available signal for maximum communications effectiveness and security.

NOTE: The telephone number and PIN number applicable to the SIM card are required in order to programme the NVM that will be used.

The SIM card (and NVM – see next page) should be inserted before power is applied. Lift the cover from the GSM module, and **CAREFULLY** insert the card into the slot provided, ensuring that it is the correct way round (angled edge to top left). Replace the cover.

At power up, the GSM (green) indicator and SIM LED (O4) will flash briefly, go off then repeat this sequence. Either indicator remaining lit indicates a fault exists.

Programming Wanderer:

Programming of the unit is carried out using 'PC-Wanderer' software to blow the required parameters into a 'Non-Volatile Memory' chip (NVM) that is then transferred to the 'Wanderer' unit. This chip **MUST** be inserted before Wanderer is powered up, or the programmed parameters will not be read.

At power up, the 'NVM' indicator (O8) will flash briefly as initialisation takes place. If this LED remains lit, initialisation has not taken place correctly.

See 'PC-Wanderer' instructions for full information.

Walk Test:

To select Walk Test mode:

Turn Keyswitch ON – OFF – ON – OFF – ON

Each time the switch is turned ON, the sounder will 'beep,' and after the final 'ON' will beep three times to confirm that the unit is in Walk Test mode.

Each time an input is activated, the sounder will 'beep' for a couple of seconds.

The walk test will respond to all detectors connected or present, even if not programmed.

To cancel Walk Test, simply turn the keyswitch to OFF.

NOTE: Any outputs programmed to switch in response to these inputs will NOT do so whilst the unit is in 'Walk Test' mode.

Operating Instructions

It is impossible to provide a standard 'Operating Manual' for Wanderer, taking into account the wide variety of applications and methods of use.

However, pages 11 and 12 briefly summarise the main points and may be removed and provided to the user, or used as the basis to produce instructions dedicated to the system as set up.

Castle Care-Tech Ltd.
North Street, Winkfield, Windsor, Berkshire, SL4 4SY
t: Sales & General: 01344 887788 Technical Support: 01344 886767
f: 01344 890024 e: sales@castle-caretech.com

Using Wanderer:

1. KEYSWITCH OPERATION

Simply turn switch to 'ON' position to set, and to 'OFF' to unset. Exit tone will be continuous in 'Normal mode,' in 'Power saving mode' single beeps will be heard at switch on and each 15 seconds. A confirmation will sound at end of exit time.

To select WALK TEST, turn switch ON – OFF – ON – OFF – ON. A triple beep will confirm this operation. Each time a detector is triggered, a beep will sound.

2. CONTROL REMOTELY

THIS FACILITY IS NOT AVAILABLE IN 'LOW POWER' MODE.

The system may be controlled by SMS messages sent to the unit from a registered mobile 'phone. Up to four numbers may be registered, and allocated individual levels of authorisation.

NOTE: SMS messages may be delayed in transmission through the messaging bureau. If remote control is to be used, it is recommended that the system be set up to confirm all relevant actions by return message to the mobile 'phone.

The following commands may be sent to the unit:

SET	Sets the system
UNSET	Unsets the system
RELAY <#> <mode>	Switches nominated output (1 or 2) to the state indicated by the 'mode' field. <i>See overleaf.</i> eg 'RELAY 1 ON' turns output 1 'on' 'RELAY 2 PULSE 30' initiates a 30 second pulse on output 2, etc.
REPORT <msg #>	Request for specific message (1 to 18 for alarm messages, 101-118 for reset messages) to be sent to all SMS users. (<i>See overleaf for table to record brief summary of the messages programmed into the system.</i>)
REPORT <msg #> ME	Request for specific message to be sent to the SMS user requesting information only
STATUS	Request for a status report on system. Includes: Site name; Set / unset status; Battery voltage; Present status of wired inputs (1 to 8)

NOTE: If the command requires an SMS reply, subsequent commands within the same message will be ignored.

OUTPUT APPLICATIONS:

1		2	
---	--	---	--

SUMMARY OF MESSAGES PROGRAMMED INTO SYSTEM:

1		101	
2		102	
3		103	
4		104	
5		105	
6		106	
7		107	
8		108	
9		109	
10		110	
11		111	
12		112	
13		113	
14		114	
15		115	
16		116	
17		117	
18		118	